

# APPLICATION TIPS

## RUBBER TRACK

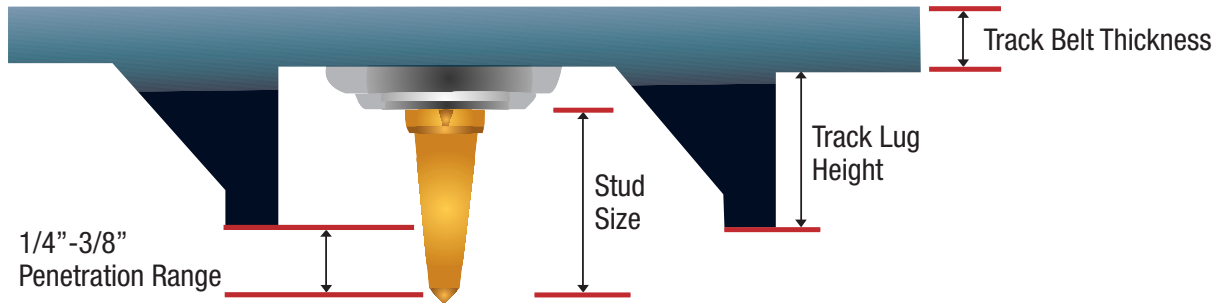

### WOODY'S PENETRATION RECOMMENDATION FOR TRAIL RIDING IS 1/4" - 3/8"

LUG HEIGHT	STUD SIZE	PENETRATION RANGE	OVERALL LENGTH	OVERALL INSTALLED HEIGHT	GOLD DIGGER® TRACTION MASTER®	MEGA-BITE®	SIGNATURE SERIES™	GRAND MASTER®
*VARIABLE -0-3%		*VARIABLE +/- .015	5/16" STUD	5/16"	5/16"	5/16"	5/16"	5/16"
0.750	*0.875	.345-.375	1.260	1.125	GDP6-8755	MEG-8755	-	-
0.820	0.875	.295-.325	1.260	1.125	GDP6-8755	MEG-8755	-	-
	*0.920	.320-.350	1.327	1.170	GDP6-9205	-	-	-
	1.000	.400-.430	1.410	1.250	GDP6-1005	MEG-1005	SSP-1005	-
0.850	0.875	.245-.275	1.260	1.125	GDP6-8755	MEG-8755	-	-
	*0.920	.310-.340	1.327	1.170	GDP6-9205	-	-	-
	1.000	.370-.400	1.410	1.250	GDP6-1005	MEG-1005	SSP-1005	-
0.880	0.875	.215-.245	1.260	1.125	GDP6-8755	MEG-8755	-	-
	*0.920	.270-.300	1.327	1.170	GDP6-9205	-	-	-
	1.000	.350-.380	1.410	1.250	GDP6-1005	MEG-1005	SSP-1005	-
0.910	*1.000	.320-.350	1.410	1.250	GDP6-1005	MEG-1005	SSP-1005	-
	1.075	.390-.420	1.485	1.330	GDP6-1075	MEG-1075	SSP-1075	GMP-1075
0.920	*1.000	.310-.340	1.410	1.250	GDP6-1005	MEG-1005	SSP-1005	-
	1.075	.380-.410	1.485	1.330	GDP6-1075	MEG-1075	SSP-1075	GMP-1075
1.000	1.000	.220-.250	1.410	1.250	GDP6-1005	MEG-1005	SSP-1005	-
	*1.075	.300-.330	1.485	1.330	GDP6-1075	MEG-1075	SSP-1075	GMP-1075
1.100	*1.175	.320-.350	1.575	1.425	GDP6-1175	MEG-1175	SSP-1175	-
1.250	*1.325	.320-.350	1.730	1.580	GDP6-1325	MEG-1325	SSP-1325	GMP-1325
1.375	*1.450	.345-.375	1.852	1.700	GDP6-1450	MEG-1450	SSP-1450	GMP-1450
1.500	*1.575	.345-.375	1.968	1.825	-	MEG-1575	-	GMP-1575

All Woody's® stud sizes are measured from the top of the Digger® support plate to the tip of the stud.  
 \* Woody's recommends .250" to .375" to be optimum penetration. Deviating from this recommendation can result in premature track wear, tunnel damage and/or loss of control.

### IMPORTANT!



Review the snowmobile and track manufacturer's studding recommendation in your owner's manual. You may void your warranty if their recommendations are not followed. Consult your snowmobile dealer about added tunnel protection.