

ATTENTION: You must read these instructions before installing aluminum runners.

Part 1 of these instructions apply to any ski recommended by International Engineering & Manufacturing in the Aluminum Runner application chart. Part 2 of these instructions apply to any ski that utilizes the runner as a fastening device to attach the ski to the saddle. Woody's Aluminum runners are designed for these applications and are not recommended for any other use.

Failure to follow these instructions could result in the loss of the ski during operation, resulting in damage to the sled, property damage, or bodily injury to yourself or others.

Part 1..... Install the Runner

- 1) Example 1 - Align the new runner bolts (c) with the hole in the ski (d) and the saddle (e). Insert the runner bolts through both pieces.
- 2) In the sequence shown below tighten the supplied runner nuts (f) from the center bolt out until the runner tightens to the ski and saddle.
- 3) **DO NOT USE AN AIR WRENCH AS THE INSTALLATION TOOL.** Use a ratchet (g) and socket to install the runner nuts.
- 4) Tighten the runner nuts on the 3/8" runner bolts with a torque wrench to 15 ft. lbs in the sequence shown below in Example 1.

After each use check the torque specifications of the runner assembly

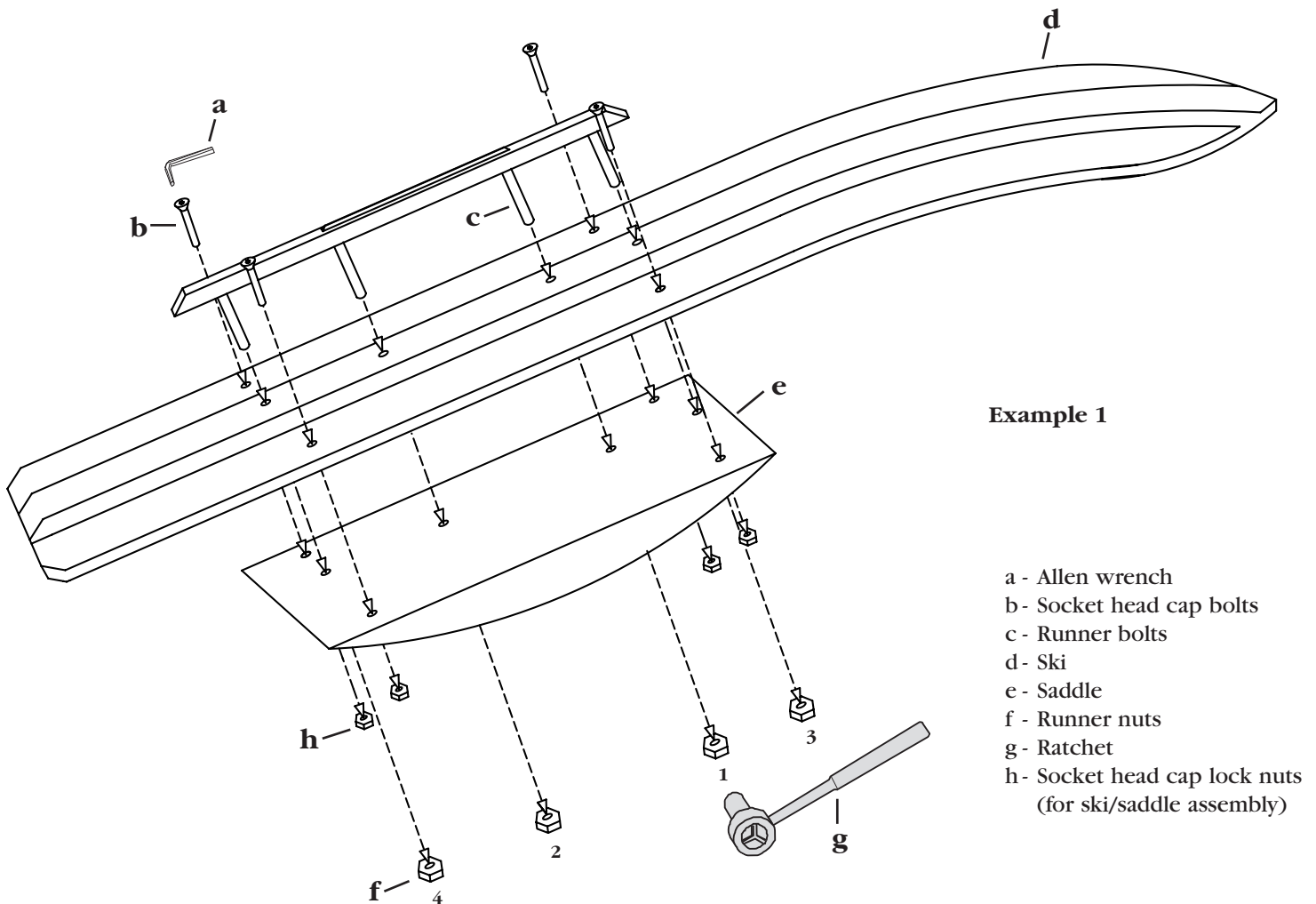

Part 2..... Ski/Saddle Assembly

To continue the assembly, you will need to drill holes that will penetrate through the ski and the corners of the saddle.

- 5) Example 2 - At each corner of the saddle (e) measure 0.75" (3/4") from the outside of the saddle and 0.75" (3/4") from the end of the saddle. Mark the top of the saddle, where these measurements intersect.
- 6) At each mark use a 17/64 bit to drill a hole completely through the saddle and ski assembly.
NOTE: REMOVE ANY BURRS OR SLAG CAUSED BY THE DRILLING TO ASSURE APPROPRIATE TORQUE SPECIFICATION.
- 7) Included in the runner package are eight 1" socket head cap bolts (b) and eight 1/4" x 28 lock nuts (h). Use four socket head cap bolts and four socket head cap lock nuts on each ski.
- 8) From the contacting surface of the ski (d) insert a socket head cap bolt (b) through the ski and saddle (e) in each of the holes drilled.
- 9) Thread the lock nuts (h) on the socket head cap bolts (b) protruding through the ski and saddle.
- 10) Insert a 5/32 allen wrench (a) into the hex of the socket head cap bolt (b), and then with a 7/16 socket and ratchet (g), torque each lock nut to 50-60 inch lbs.

Example 2
(top view of saddle)

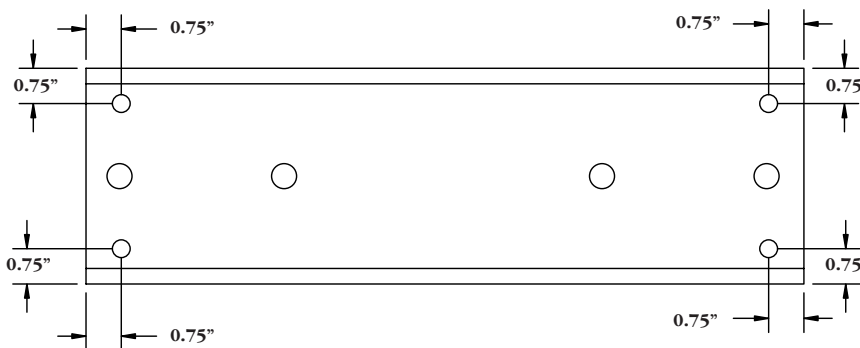

- 11) Example 3 - Once tightened, determine if all four socket head cap bolts are recessed or flush with the contact surface of the ski. For any socket head cap bolts that are not flush or recessed, increase the torque until the bolts are recessed or flush.

After each use, check the lock nut torque of the bolts fastening the ski and runner.

Example 3

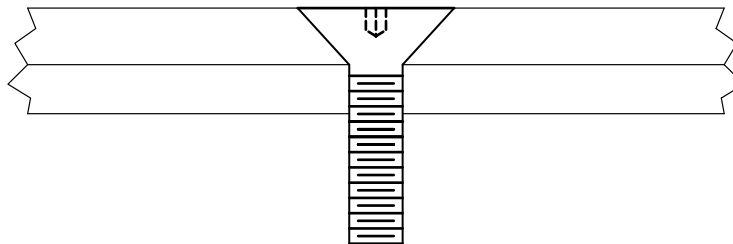

- a - Allen wrench
- b - Socket head cap bolts
- c - Runner bolts
- d - Ski
- e - Saddle
- f - Runner nuts
- g - Ratchet
- h - Socket head cap lock nuts (for ski/saddle assembly)